

CHATTANOOGA'S

KICKSTAND UP!

The Scenic City's Motorcycle Heart Beat

MAGAZINE

FEBRUARY 2012

FREE



Pandora's European Motosports
presents

PISTONS
&
FENDERS



to benefit the Austin Hatcher Foundation for Pediatric Cancer.

KickStandUp.com

See Page 18

**ACCIDENT?
Hire the Attorney
Who Rides...**

**...AND Returns
Phone Calls!**



**Free Legal Consultation
No Fee On Motorcycle
Damage Recovery**

Motorcycle Accidents - Car Wrecks - Criminal Defense

Law Offices of Johnny D. Houston, Jr.

707 Georgia Avenue, Suite 301

Chattanooga, TN 37402

LOCAL 423-267-6715 TOLL FREE 866-384-5646

www.TheBikerAttorney.com



CAUGHT IN HEADLIGHT

Coker Tire Museum



Kim Teems





ROAD MAP

Road Map Photo
 Photographer: Gregory Cook
www.gregorycookphotography.com

KSU Community Snapshots	7
MC Club in the Headlight – Steel Brothers.....	9
Family Vintage Photo	13
Product Review	14
Pandora’s Pistons & Fenders	17-19
Advertisers Index.....	15
Event Listings	16
In The Rearview Mirror – Vintage.....	20
Women in the Wind – Tabatha	22
In The Headlight – Jessi.....	25
Back Roads	30
Rides & Rods.....	32
Classifieds	35

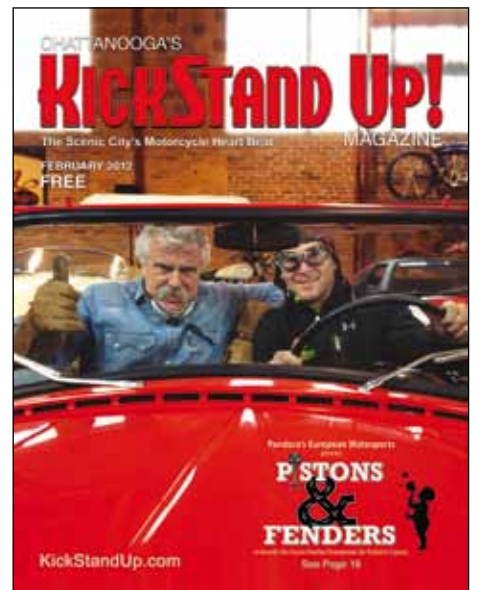

Cover: February 2012
Corky Coker & Justin Prann during PSA
 filming for the Pistons & Fenders Event
 See page 17-19
 Photographer: AmyJo Osborn
www.hatcherfoundation.org



Janet H.

FROM THE EDITORS

I have been asked on more than one occasion why we cover motocross and feature kids in our magazine. Well I'm going to tell you and set the record straight. You see, motorcycling in most cases is a life long interest. Once you've ridden on a bike . . . well . . . there's nothing like it. Lucky kids have parents that start them riding early. The only place a kid can ride legally, before they're 16, is on private property or on motocross tracks. They ride dirt bikes. KSU wants to encourage kids to ride. We want to encourage parents to teach your kids to ride and give them a gift that keeps on giving. You see, kids are our future and the future of motorcycling. Without them, our species of thrill seekers/adventurers will die. Encourage a kid to ride.

Now I don't ride dirt bikes anymore, but I love all things motorcycle. Hence, the last couple of years I've started watching Supercross on Saturday nights. If you want to see some real athletes and daredevils, give it a try. It's fast and exciting . . . and dirty.

Since buying my first sport bike a year and a half ago, I've also developed a passion for watching MotoGP each week during the season. These guys are real warriors, riding extremely high tech and powerful machines. This ain't NASCAR people, these guys are on two wheels running as fast or faster than stock cars. There's no seat belts and shoulder harnesses either. While the car jockey's pull into the pits when it starts raining the world class MotoGP riders just keep on racing. It's amazing to watch and poetry in motion as the riders change body positions on their bikes and the pack moves around the track. These guys ride so close together yet they have no mirrors. I've seen riders actually tap the leg of the guy on the inside with their glove as they attempt to pass on the outside. MotoGP racing is broadcast live on the Speed Channel on Sunday mornings around 8 a.m. Races are over in one hour.

Well, I don't know what the real point of this article was, other than to show you that even old guys can try something new. Trying new things is what keeps people young. If you ride, get on something different. If you haven't ridden that road, ride it. If you don't ride, give it a try. I want to live life to the fullest and have no regrets when I really get old (and my definition of old changes every year.)

LTRATSN,
Ronnie "Rock" Land
Ronnie@kickstandup.com

Yay – it's February and getting closer to springtime every moment; my favorite riding time! I love the mixture of extremes from morning to night and the layers of gear to accommodate Mother Nature's whimsical taste. Yep, February is a good month for getting geared up.

Saturday, February 4, starts the month off with a bang with **Pandora's Pistons & Fenders** event, benefitting the Austin Hatcher Foundation. It's at the Coker Tire Museum this year and Corky Coker will be there auctioning off a plethora of cool items. Check out pages 17-19 to read more about the event, why Pandora's European Motorsports chose the Austin Hatcher Foundation, and what exactly the foundation does. I can't wait to check out the museum again, and oh did I mention all the food and drink you can handle too? It's sure to be an evening of fun and interesting bikes and people. Hope I see you there!

Another fun event coming up on Saturday, February 11, is the **N. GA ABATE Chili Cook-off** on Saturday, Feb. 11. They always put on a good time with lots fun and friendship and I hope to make this event too. I love my North Georgia ABATE community. Read more on page 12.

No matter what the weather, on bike or in a car, you'll always find good entertainment in a relaxing atmosphere at **Jim Oliver's Smokehouse**, in Monteagle, TN. They have Nashville entertainment every weekend and are hosting a songwriting workshop as well. If you want to stay the night they have rustic cabins and a Best Western Lodge with great prices. Check out page 34 and see what they have in store for the season.

Spring Roughnecks - the words just seem to go with each other! Save the date for Saturday, March 17 and one of the first rides this spring. You won't want to miss the **Jarrett Little Memorial Poker Run**. The Roughnecks always put on a good ride.

A birdie from Sand Mountain told me that there will be another **Bama Swap n Drag** on March 31st at Sand Mountain Dragway. I wasn't able to make their first one because of magazine deadline, but I've got this date marked in ink and I'm looking forward to seeing all the cool bikes and hot rods. I just love a good drag race - Oh the smell of burning rubber! Look for more info in the March issue of KSU.

Well I hope you're as geared up as I am about the upcoming months. It's sure to be lots of good wind time. I myself aim to ride to quite a few adventures in the upcoming months. Hope to see you out there!

See ya in the wind,
Kim "HippyChicKim" Teems
kim@kickstandup.com

"There is no end. There is no beginning. There is only the passion of life."

~ Federico Fellini



Kim Teems

CHATTANOOGA'S

KICKSTAND UP!

The Scenic City's Motorcycle Heart Beat

MAGAZINE

STAFF

Ronnie Land, Editor

ronnie@kickstandup.com / 423.400.6419

Kim Teems, Editor

kim@kickstandup.com / 423.774.0549

Jimmy Cornett, Distribution

jimmy@kickstandup.com / 423.400.2635

Julie Land, Proof Reader

julie@kickstandup.com / 423.400.5217

WRITERS

Zack Cummings

Jeff Gates

Jeff Griffith

Darlene Jacks

Ronnie Land

Jim Lozon

Doug McGlumph

Mark Moore

Justin Prann

Kim Teems

Danny Thompson

Chuck Welch

Kent Whitaker

PHOTOGRAPHERS

Gregory Cook

Jimmy Cornett

Zack Cummings

Bob Edens

Janet H.

Cheryl Lozon

Jim Lozon

Karen McDonald

Doug McGlumph

Frank Pate

Kim Teems

Killboy

Chuck Welch

Kent Whitaker



STAFF



Kim Teems

Sales & Event Coverage

423.774.0549

kim@kickstandup.com



Chuck Welch

Sales & Event Coverage

423.322.4105

chuck@kickstandup.com



Sandy Hoffman

Sales & Event Coverage

423.240.1919

sandy@kickstandup.com



Alan Kelley

Sales & Event Coverage

423.903.2068



Jeff Griffith

Motocross Editor

423.902.1256

jgriffith@griffithcycle.com



Greg Cook

Event Coverage

423.716.1657

greg@kickstandup.com



Frank Pate

Event Coverage

423.598.9441

frank@kickstandup.com



Lori Cornett

Facebook Queen

423.667.9329

lori@kickstandup.com



Hugh "Hey U" Teems

Interstate Distribution

& Chief Promoter

©2012 KickStand Up! Magazine is published monthly. All rights reserved. No part of it's content may be reproduced without written permission. KickStand Up! logo ©2012. Publisher assumes no responsibility and should not be held liable for errors beyond the financial cost of the space occupied by the error, slander of any group or individual, failure to produce any issue as scheduled due to reasons beyond their control, any and all suits for liable, plagiarism, copyright infringement and unauthorized use of a person's name or photograph. Opinions and claims made by advertisers and authors are their own, and do not necessarily represent the policy of KickStand Up! LLP. Publisher does not promote the abuse of alcohol or other drugs.

February 2012

Issue 15

Published by

KickStand Up! Magazine LLP

3472 Brainerd Rd.

Chattanooga, TN 37411

www.KickStandUp.com

SUBSCRIPTIONS AVAILABLE

KickStand Up! Magazine delivered to your doorstep for One Year just \$40

Subscribe online at

www.KickStandUp.com

Or send Check or Money Order to:

KickStand Up! Magazine

3472 Brainerd Road

Chattanooga, TN 37411



KSU Community

SNAPSHOTS



Unwanted MC
Just a Bunch of Teddy Bears!

Frank Pate

In 2001, eight friends got together at a local watering hole and decided they wanted to form a motorcycle club. After much discussion, and going through the proper channels the UNWANTED was formed. A concept, which at that time was unheard of having. Police, firemen, military, and civilians all riding together. Not long after the formation of the club, they decided to make **Children's Hospital** their charity of choice. Numerous rides have happened since then.

Around about 2004, the club thought what a great idea it would be to take teddy bears up to the kids on Christmas Eve. As if for a child being in the hospital wasn't bad enough, to be there at Christmas was

truly sad. The first couple of years it was simply stuffed animals of all kinds. After a couple of years like that, the club made contact with Build A Bear. Then all of the bears would be in uniform. The children could name them on birth certificates and hopefully have a joyful memento of their hospital stay at Christmas time.

The strange thing is that the club giving the bears out has become more of a gift to the members than anything else. More than one member has come out of the emergency and the children's ward both sad at what they have seen. Yet they are happy to have given a little joy to the children that are there at Christmas.

Introducing **KSU Community Snapshots**...A place for you to share your two and three wheel triumphs, thoughts, and memories. Submit your comments and photos [try to keep it to 100 words or less with optional one photo - including photographers name - per comment] to KSU by email to kim@kickstandup.com

or snail mail to:
KickStand Up! Magazine
3472 Brainerd Road
Chattanooga, TN 37411

*Subject to KSU approval and space availability.



1111 McFarland Ave., Rossville, GA 30741
706-858-7427
HowardHeatingAndAir.com



Each month we are giving KSU gear to the first person to pull the new issue out of our 24/7 rack. The magazines hit the rack around the 28th of every month. When the new issue arrives the KSU flag will be flying above our rack in front of the Quick Tees building at 3472 Brainerd Road. Be the first person to get the new issue and win a prize along with getting your photo in next month's magazine.

January Winner David Robinson of Chattanooga, member of the GWRRA



BLACKSMITH'S
BISTRO & BAR

3914 st. elmo avenue
chattanooga, tennessee
open: wed. - sat. - 11:am - 10:pm
SUNDAY BRUNCH
11:am-3:pm
423.702.5461
kelly and blackwell smith
owners
caffeinechatt@gmail.com

CAGLE MOUNTAIN TRADING POST
(Formerly Laura's Market)

HWY 111
Alop Cagle Mtn., TN

Motorcycles Welcome

Pizza	Biscuits	Fuel
Ice	Sandwiches	Bait
	Cold Beer	
	Clean Bathrooms	

423-949-5063

CMT/ ABATE



WHAT'S IN STORE FOR 2012

The Tennessee 2012 legislation has begun and the political organization **CONCERNED MOTORCYCLIST OF TENNESSEE/AMERICAN BIKERS ACTIVE TOWARD EDUCATION [CMT.ABATE]** will be there protecting your right to ride.

For the 2012 legislative season CMT/ABATE will be working on passing two bills.

The first one is **"THE FREEDOM OF CHOICE BILL"** this bill will allow 21 and over to ride without a helmet.

We would like Tennessee to become the 31st state that

allows you to choose what to wear when riding your motorcycle. We have been working diligently with members of Tennessee Legislature and feel that we have a good chance of getting this bill to pass but there is still a lot of work to do.

If the motorcyclist of Tennessee wants this to become a reality your State Representative and State Senator will need to hear from you this year.

The second bill we'll be working on would expand the **"DUE CARE LAW"** to include all who use Tennessee's roadways.

At this time the "Due Care Law" can make violating a bicyclist or pedestrians right away that results in injury or death a Class A misdemeanor, which can carry a jail time up to 11 months and 29 days and a fine up to \$1000. The fine for violating a motorist right away that results

in death or injury can be a Class B misdemeanor which can carry a jail time of up to 6 months and a \$500.00 fine. To give you some perspective on this getting caught doing a wheelie carries a fine up to \$500.00 with no one getting injured. Are we not worth more than \$500.00?

As always we will monitor any legislation that affects motorcyclist here in Tennessee. If you would like to learn more check out our web site **www.cmtabate.com** or you can **attend our meetings** that are held on the 3rd Sunday of the month at Spectators Grill and Bar located on East Brainerd Rd at 2:00 p.m.

Ride safe
Mark "Yog" Moore
CMT/ABATE Tennessee Valley
Charter Director

POWERSPORTS UNLIMITED
423-842-3478

Jet Skis • ATV's • Cycles
Parts • Service • New & Used Sales

8521E Hixson Pike
Hixson, TN 37343
423-842-3478

Hilltop HOTEL
Conference Center
SWEETWATER, TN / EXIT 60
MOTORCYCLE FRIENDLY Rider Discount

DBL Room Reg. \$45.99 Discounted \$43.76
King Beds Reg. \$49 Discounted \$45.99
FREE CONTINENTAL BREAKFAST

180 New Highway 68 / Exit 60
Sweetwater, TN 37874
423-337-3511
hilltophotelusa.com

Red Bank
wine & spirits
ALLYN PRUITT, Owner

3849 DAYTON BLVD. - SUITE 113
RED BANK, TN
423.877.1787

STEEL BROTHERS



CHATTANOOGA, TN

have stood solid and remained a close knit family. **STEEL BROTHERS MC** was created to improve the image of the motorcyclist within the MC community and general community, while focusing on creating a stronger brotherhood within our own families. We actively participate in

was host to over 270 vehicle participants and over 540 people [see photos on page 39] in 2011! We also sponsor the **BIG HEARTS FOR LITTLE HANDS MOTORCYCLE RALLY**. Our first two years with Big Hearts benefited the NICU at TC Thompsons and raised over \$8000. We are proud to announce this year Big Hearts will have a new beneficiary, **LANA'S LOVE FOUNDATION**. Lana's Love Foundation focuses on helping local families with children diagnosed with cancer escape the every day routine they must endure.

Steel Brothers MC is a kid-friendly, family-oriented club. We originated in 2008 and have already seen our share of rough times but

benefits for the needy or less fortunate. We have sponsored the **CHATTANOOGA TOY RUN** since 2009. The toy run benefits the Chambliss Shelter, which

If you are interested in becoming a part of our family, feel free to contact us: crash@steelbrothersmc.com.



If you're buying a new ride or customizing one, I can help you save money insuring it. To make sure you're fully protected, Allstate automatically gives you \$1000 of coverage for aftermarket items. Call me today.



Keith M. Thompson, FLMI, CLTC
(423) 899-3140
400 S. Moore Rd.
Chattanooga
a059045@allstate.com



Insurance is subject to qualifications, conditions and availability. Discount is subject to qualifications and availability and amount may be lower. Allstate Property and Casualty Insurance Company, Northbrook, IL. © 2009 Allstate Insurance Company

COLOR FLYERS
29¢ Each
[Regular 43¢ Each]
Mention This Ad When Ordering
Offer Expires 2/29/2012
On 60# paper using your artwork

The PRINT SHOP
706-861-5088
www.the-print-shop.net
110 Herron Street
Fort Oglethorpe, GA 30742



Kim Teems

DW'S - A Small Shop With A LOT OF STUFF!

Come on out and take a little ride to DW's Accessories, at 14402 Dayton Pike/Hwy 27, in Sale Creek, TN. It's a cool little shop with LOTS of MOTORCYCLE paraphernalia for ALL types of riders! DW's has been serving the motorcycle community since 1999 and is an official Trail of Tears approved vendor for TOT shirts, patches and pins. You'll find down home value with a variety of items, including a neon Betty Boop clock and other Betty Boop swag, bandanas, jackets and gloves, helmets, motor oil, brakes, tires and more. You'll be surprised to find that DW's is competitive with Internet prices and you get to deal with a live person who'll back up their product.

Remember – Shop Local and Keep the American Dream alive and well!
DW's Accessories, 14402 Dayton Pike/Hwy 27, Sale Creek, TN, 423-332-0007, www.dwsmotorcycle.com

30 Seconds with KSU Advertisers

Each month, KSU advertisers introduce themselves to you so you can get to know them a little better.

 **Elke's Hair & Nail Salon**
 COUPON - COUPON - COUPON
SEVEN FOIL HIGHLIGHT & CUT
\$43.00 with coupon
 Good through February 2012

KickStand Up! Special
 Ride Your Bike or Mention KickStand Up!
GUYS CUT for \$10
GALS CUT for \$20

423-875-2551
 5519 Hwy 153 Suite 6
 Hixson, TN 37343

DW'S MOTORCYCLE ACCESSORIES



Helmets, Gloves, Sunglasses, BETTY BOOP, Accessories, Jackets, Bandanas, Tires, Trail of Tears T-shirts, Pins, Bike Cleaner, Stickers, & More!

VALENTINE'S SPECIAL 15% OFF EVERYTHING IN THE STORE WITH THIS AD!
 Excludes oil & tires 'cause we already sell them so cheap!
 Good For The Month of February

SHOP LOCAL KEEP THE AMERICAN DREAM ALIVE

14402 DAYTON PIKE / HWY 27, SALE CREEK, TN 423-332-0007
WWW.DWSMOTORCYCLE.COM



Family Owned & Operated
 Ask for Frankie or Johnnie
 This area's most affordable and "laid back" Super Store

Possibly the "World's Greatest Handcrafted Candles"

Sony ~ Kicker ~ SPL ~ Pioneer
Pyrie ~ Lanza ~ Crunch USA
JVC ~ Kenwood ~ Audiopipe
MTX ~ Power Acoustic

Servicing The Chattanooga area for over 30 years.
423-504-9874 / 423-394-0565

Everything Under Warranty!

STEREO CITY
CAR AUDIO & GIFT SHOP
 (Next to East Ridge Flea Market)

OPEN 7 DAYS
 6725 Ringgold Road, Suite B
 East Ridge, TN 37412



Tom's Tree Service Crew from left to right: Tommy Hegwood, Daniel Fraisher, Steve James, Kim Hegwood, Jeremy "JR" Hegwood

TOM'S TREE SERVICE **ALWAYS CLIMBING HIGHER TO SERVE YOU BETTER!**

Tom's Tree Service is a family owned and operated business based in Rock Spring, GA. It was established in 1960 by Tom Hegwood, then passed on to Kim Hegwood when his father retired. Tom's Tree Service does everything from tree cutting, tree and stump removal, to bucket and crane services. We are fully insured!! Thank you for your business. We look forward to serving you in 2012.

Tom's Tree Service, 706-764-9960 or 423-432-6384



Gregory Cook

TOM'S TREE SERVICE
 "Always Climbing Higher to Serve You Better"
 Kim Hegwood
 Complete Tree Service
 Insured - Bucket Truck
 Stump Removal
 Office: 706-764-9960
 Cell: 423-432-6384



Jimm Cornett

Johnnie and KSU Facebook Queen Lori cheese it up.

WELCOME BACK STEREO CITY!

Need a stereo system for your car? Need a unique, cool gift for your other half? Stop by **Stereo City** in East Ridge and ask for Frankie or Johnnie. You'll walk out with a great deal and a smile on your face!

Stereo City, 3725 Ringgold Road, Suite B, 423-504-9874 or 423-394-0565

ess **CARTER'S SHOOTING SUPPLY AND RANGE**
 6210 Hwy. 58 N - Harrison, TN
Personal One-to-One Training in an Indoor Range!



- Tennessee Handgun Permit Class
- Hunter Safety Course

Phone: [423] 344-1099
 Fax: [423] 344-1097
CARTERSHOOTING.COM

21st Annual ABATE

Chili Cook-Off & Hard Times Dance

Well, here it is January, New Year's and Christmas have passed and we, motorcyclists in general, are waiting for spring



to get here or at least a moderately warm day from time to time, so we can meet up with friends or family or go solo and ride our bikes. Never fear though, there is an event that has been held for the last 20 years in North Georgia that you are sure to enjoy. Ride or Drive, it's all the same for this event, just be there.

ABATE of GA, District 1 has been holding a Chili Cook-Off and Hard Times Dance in various venues for the last 20 years and they would love for you all to come out and enjoy an evening inside with fantastic chili of all kinds, **Saturday, February 11**. Some so hot you don't understand how anyone can eat them. There will be a live band playing and the dance floor will be calling.

There will be a secret ballot of which chili is the best or hottest. If you want to enter your own secret recipe the rules are simple. Bring an empty clean crock pot, your completed chili in another pot (you may want to bring a lot), and a serving/dipping spoon to the Legion Hall in Chatsworth, GA. Bring your chili warm



as there is no kitchen available at this venue. All of the entrant's pots will be taken behind the 'secret curtain' where someone else's chili may end up in your crock or vice versa and they will be numbered so everyone just votes for a number.

Please have your chili there between 7:00 and 8:00 PM. There is no cost to enter the contest. The cost to enter the event is \$10.00 per person and it last from 7:00 PM until Midnight. For more information please look at the events page or call Heidi Stockwell @ (706)217-8317 or Roxanne Black @ (706)934-3160.



Hope to see you all there.
Ride Safe.
Jeff Gates

ALLSTATE TRAILERS - 893-8000



FOR ALL YOUR TRAILERING NEEDS



allstatetrailers.com

2123 Storage Rd.

Chattanooga, TN 37421

(Next to Comcast on Hwy 153)

**CALL
Randy**

893-8000



ASK YOUR NEIGHBORS

Twilley Chiropractic Center
4830 Hwy 58 east of Hwy 153
Near Food Lion
Monday thru Friday 10AM to 7PM
In practice since 1980

Drugless treatment for trigger points, fibromyalgia, osteoarthritis, bursitis, back pain, neck pain, and all types of headaches. Prompt referrals for non-responsive conditions (1 to 3 visits). Average cost of first visit, including initial exam, is \$78. Children younger than 14 treated free if one other family member is a patient.

The Doctor has been a runner for over 40 years and understands exercise. "Ask your neighbors"....

423-899-6941

Vintage Family Motorcycle Photos

We asked for it and we got it! Keep them coming! If you have some cool motorcycle photos of you or your family from days gone by send us an email at kim@kickstandup.com along with a copy of the photo, or drop by Quick Tees and have Ronnie scan it. You never know... your shot may end up here!



Walnut Street Bridge area – Chattanooga, TN. My grandparents - Charlie & Irene McKeel. Charlie delivered pharmaceutical drugs on this bike in the 1920s.

~ Ray McKeel

PRODUCT REVIEW



SUPERQUADRO

The new Superquadro engine is claimed to be the most powerful twin-cylinder in production. The Superquadro is named after its highly oversquare 112 X 60.8mm L-Twin. Besides its standard L-configuration and Desmodromic valve control system, Ducati started with a clean slate for the powerplant. Ducati rotated the top end of the signature 90-degree L backwards around the crankshaft which gives six-degrees more clearance on the front wheel and allowed the front-to-rear bias

to be skewed slightly to a 52% front bias. It also perfectly positioned the cylinder head attachments with the monocoque frame. The primary-drive and clutch casings, sump and cam covers are cast in magnesium alloy for weight savings. The crankcases use a shell main bearing for the crankshaft, a feature reserved for

the Desmosedici RR engine up till now, while the top of the crankcase apertures have separate nikasil-coated aluminum wet-liners. Its inlet valves have been switched to titanium from steel and the diameters of both inlet and exhaust valves have increased, bumping up intake from 43.5 to 46.8mm while the exhausts are

now 38.2mm, up from its previous 34.5mm measurement. The original belt-drive of the Desmodromic system has been replaced by a combined chain and gear-drive arrangement in order to control such large valves.

The chassis itself is frameless, with the swingarm being bolted directly to the engine cases and the carbon fiber headstock being bolted to the cylinder heads.

We at the Pandora's are all very very excited for this new machine. Stay tuned as first deliveries are slated for mid-March!

Justin Prann
justin.prann@pandorasmotorsports.com

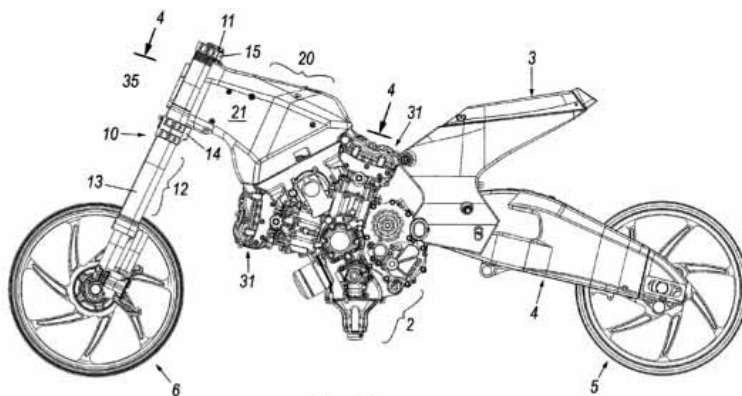

HAWG WILD
BUY
SELL
TRADE
 New & Used
HARLEY PARTS
 Complete Engine Service
706-861-0313
 922 LaFayette Road Rossville, GA 30741

LARGE GROUPS WELCOME
(706) 745-9519

Mike's

Seafood Market & Grill

121A Murphy Highway - Blairsville, Georgia

From Chattanooga - Take 64E to Flea Market at Ranger, NC - go R on 129 - about 14 mi. on right

Monday - Saturday

Market Hours:	Grill Hours:
10 am - 9 pm	Lunch - 11 am - 2 pm
	Dinner - 5 - 9 pm



Kent Whitaker

Kent's Easy Baked Italian Chicken & Pasta

Looking for a dinner for two that is simple, small in portions, full of flavor and easy to make for Valentine's Day? Well, here is a suggestion that fits the bill. The idea behind this dish is quick and easy with little cleanup so you and your better half can have time for other things besides doing dishes and staying in front of the stove for hours. Another plus is that you can substitute several ingredients or apply the basic idea to one of your favorites.

Make the chicken and pasta in small portions, use pre-cooked chicken if possible, use basic ingredients and seasonings and the cheese of your choice. The salad adds an extra layer of flavor and the wine adds a special touch. I'll leave the dessert up to you.

- Kent's Easy Baked Italian Chicken and Pasta - Serves two**
- 1 cup cooked chicken chunks**
- 1 1/2 cups cooked wheat pasta**
- Italian seasoning**
- Minced garlic**
- Olive oil**
- Italian Blend Shredded Cheese**
- Flavored tomato sauce if desired**
- Chopped tomato or peppers if desired**

Cook or thaw precooked chicken chunks season with Italian seasoning and set aside. Cook pasta as per directions on box. In a pan sauté chicken, minced onion and additional small amounts of onion, pepper etc. Use small amounts, chopped fine. Saute in olive oil. Combine with noodles, toss with tomato sauce if desired, place into small carafe dishes or small baking dish with non-stick spray. Top with cheese and bake at 375 until cheese bubbles. Serve warm, careful single serve dishes will be hot! Feel free to add your favorite spices etc.

Kent Whitaker is a Cookbook author and culinary writer with eight books. He is also member of, and, an AUXCHEF trainer for the United States Coast Guard Aux. He and his wife Ally consider themselves as recreational riders and live in East Tennessee. Kent's books are available at any book store or online at www.thedeckchef.com or on twitter at www.twitter.com/theKentWhitaker

ADVERTISER INDEX

A Better Choice Chiropractic	16	Kirk's Cycle	24
Allstate / Keith Thompson.....	9	Mike's Seafood	14
Allstate Trailers	12	Mountain City Landscape	23
American Trading Post & Grill	21	Mountain Creek Harley-Davidson.....	40
Autocycle Powder Coating	35	Pandora's European Motorsports.....	19
Blacksmith's Bistro	7	Pistons & Fenders	17
Buddy's Shoe Repair.....	22	Powersports Unlimited.....	8
Cagle Mountain Trading Post.....	7	QuickTees.....	28
Carter's Shooting Supply & Range	11	Red Bank Wine & Spirits	8
Dallas Bay Baptist Church.....	36	Sequatchie Valley Wine & Spirits	32
Dead Girlz Tattoo & Boutique	33	Smoke House Restaurant	34
Dodd and Associates Training	29	State Farm.....	36
Dr. Dan Twilley.....	12	Stereo City.....	10
DW's Motorcycle Accessories	10	Stroker Cycle	30
East Brainerd Wine.....	15	The Hogs Pen.....	22
Elke's Hair & Nail Salon.....	10	The Print Shop.....	9
Garry Griffith Cycle	27	Thunder Creek Harley-Davidson.....	40
Hawg Wild	14	Tom's Tree Service	11
Hilltop Hotel	8	Trail of Tears Ride to Remember.....	33
Howard Heating & Air	7	Tri-State/Amsoil	35
Hudlow Axle.....	35	Wisteria Cafe	36
Johnny Houston.....	2	White Cotton Leather Co.....	32
Killboy.....	29		

**East Brainerd
Wine & Spirits**

**7804 East Brainerd Road (In Bi-Lo Plaza)
Chattanooga, Tennessee
423-855-4120**

Family Owned, Robert & Valorie Cox

EVENT LISTINGS

FRIDAY, FEBRUARY 3

Monteagle, TN
SMOKE HOUSE LIVE NASHVILLE MUSIC
 850 West Main St.m
 6:30pm-9:30pm CST - NO COVER!
 www.TheSmokeHouse.com

SATURDAY, FEBRUARY 4

Chattanooga, TN
PANDORA'S EUROPEAN MOTORSPORTS PISTONS & FENDERS
 to benefit The Austin Hatcher Foundation for Pediatric Cancer
 The Coker Tire Museum, 6 pm
 hatcherfoundation.org/pandora

Monteagle, TN
SMOKE HOUSE LIVE NASHVILLE MUSIC
 850 West Main St., 6:30pm-9:30pm CST - NO COVER!
 www.TheSmokeHouse.com

Knoxville, TN
EASYRIDERS BIKE SHOW TOUR
 Knoxville Convention Center
 800-962-9857
 www.EasyridersEvents.com

SATURDAY, FEBRUARY 11

Chatsworth, GA
ABATE OF GA DISTRICT 1, 21ST ANNUAL CHILI COOK-OFF
 American Legion in Chatsworth, GA
 7:00 PM - 12:00 PM,
 (706)217-8317 (706)934-3160

Chattanooga Tn
WOMEN ON WHEELS(R) MEETING
 Magoo's East Ridge, 11 AM
 Joanne Peek
 joandcharlie@epbf.com, www.coolladycruisers.com

FRIDAY - SUNDAY, FEBRUARY 12, 11, & 12

Monteagle, TN
LOUISA BRANSCOMB & FRIENDS SONGWRITING WORKSHOP MONTEAGLE MOUNTAIN MASTERCRAFT SERIES #1
 Smoke House, 850 West Main St.
 6:30pm-9:30pm CST
 www.SuccessfulSongwriting.com

FRIDAY, FEBRUARY 17

Monteagle, TN
SMOKE HOUSE LIVE NASHVILLE MUSIC
 850 West Main St., 6:30pm-9:30pm CST - NO COVER!
 www.TheSmokeHouse.com

SATURDAY, FEBRUARY 18

Monteagle, TN
SMOKE HOUSE LIVE NASHVILLE MUSIC
 850 West Main St., 6:30pm-9:30pm CST - NO COVER!
 www.TheSmokeHouse.com

FRIDAY, FEBRUARY 24

Monteagle, TN
SMOKE HOUSE LIVE NASHVILLE MUSIC
 850 West Main St., 6:30pm-9:30pm CST - NO COVER!
 www.TheSmokeHouse.com

SATURDAY, FEBRUARY 25

Monteagle, TN
SMOKE HOUSE LIVE NASHVILLE MUSIC
 850 West Main St., 6:30pm-9:30pm CST - NO COVER!
 www.TheSmokeHouse.com

FRIDAY, MARCH 2

Monteagle, TN
SMOKE HOUSE LIVE NASHVILLE MUSIC
 850 West Main St., 6:30pm-9:30pm CST - NO COVER!
 www.TheSmokeHouse.com

SATURDAY, MARCH 3

Monteagle, TN
SMOKE HOUSE LIVE NASHVILLE MUSIC
 850 West Main St., 6:30pm-9:30pm CST - NO COVER!
 www.TheSmokeHouse.com

FRIDAY, MARCH 9

Monteagle, TN
SMOKE HOUSE LIVE NASHVILLE MUSIC
 850 West Main St., 6:30pm-9:30pm CST - NO COVER!
 www.TheSmokeHouse.com

SATURDAY, MARCH 10

Monteagle, TN
SMOKE HOUSE LIVE NASHVILLE MUSIC
 850 West Main St., 6:30pm-9:30pm CST - NO COVER!
 www.TheSmokeHouse.com

FRIDAY, MARCH 16

Monteagle, TN
SMOKE HOUSE LIVE NASHVILLE MUSIC
 850 West Main St., 6:30pm-9:30pm CST - NO COVER!
 www.TheSmokeHouse.com

SATURDAY, MARCH 17

Rossville, Ga.
JARRETT LITTLE MEMORIAL POKER RUN
 Rossville City Park Salem Rd
 Paw Paw 423-762-0133, roughnecksmc.com

Monteagle, TN
SMOKE HOUSE LIVE NASHVILLE MUSIC
 850 West Main St., 6:30pm-9:30pm CST - NO COVER!
 www.TheSmokeHouse.com

FRI - FOLLOWING SUN., MARCH 9 - 18

Daytona, FL
DAYTONA BIKE WEEK
 www.officialbikeweek.com

FRIDAY - SUNDAY, MARCH 23, 24, & 25

Monteagle, TN
SMOKIN HIT SONGWRITERS SEMINAR/RETREAT
 Smoke House, 850 West Main St.
 6:30pm-9:30pm CST
 www.SmokinHitSongwriters.com

FRIDAY, MARCH 30

Monteagle, TN
SMOKE HOUSE LIVE NASHVILLE MUSIC
 850 West Main St., 6:30pm-9:30pm CST - NO COVER!
 www.TheSmokeHouse.com

SATURDAY, MARCH 31

Section,AL
ANNUAL BAMA SWAP N DRAG
 Sand Mountain Dragway
 Motorcycle n Car Parts Swapmeet, Show, & Drags
 Gates open at 9 am
 Michael 256-630-8129, Rick 256-638-1069.
 www.violentchoppers.com

Monteagle, TN
SMOKE HOUSE LIVE NASHVILLE MUSIC
 850 West Main St., 6:30pm-9:30pm CST - NO COVER!
 www.TheSmokeHouse.com

FRIDAY, APRIL 6

Monteagle, TN
SMOKE HOUSE LIVE NASHVILLE MUSIC
 850 West Main St., 6:30pm-9:30pm CST - NO COVER!
 www.TheSmokeHouse.com

SATURDAY, APRIL 7

Madisonville /TN
FULL THROTTLE WARRIORS BIBKE BLESSING
 OAA Worship 876 Englewood Road
 Registration 10 Blessing at 11:30
 Morgan Clough 423 807 1777

WEDNESDAY - SUNDAY, MAY 2-6

THUNDER BEACH RALLY
 Panama City Beach, FL
 www.thunderbeachproductions.com

FRIDAY - SUNDAY, MAY 25, 26, & 27

Monteagle, TN
THUNDER ON THE ROCK MUSIC FESTIVAL AND BIKE RALLY
 Andrea Layne 423-304-5246
 www.thunderontherock.net

THURSDAY - SUNDAY, JULY 26 - 29

Carson City, NV
2012 AMA WOMEN & MOTORCYCLE CONFERENCE
 (614) 856-1900
 www.americanmotorcyclist.com/events/womenandmotorcycling

WEDNESDAY - SATURDAY, AUGUST 16-10

Franklin, NC
SMOKY MOUNTAIN RUMBLE
 Vendors, poker runs, guided rides, entertainment and much more in downtown Franklin NC
 Sylvia 478-237-3761
 www.smokymountainrumble.com

Enter Your Event at
KickStandUp.com/events.html

FREE Exam & X-Rays for New Patients

Got more Kinks than the Dragon's Tail?

A Better Choice Chiropractic
 The Doc Who Rides! Dr. Troy R. Smith, DC
 4922 Brainerd Road, Chattanooga, TN
 423-499-8834
TroySmithChiro.com

Pandora's European Motorsports
presents

P STONS & FENDERS

to benefit the Austin Hatcher Foundation for Pediatric Cancer.

If you like anything that goes fast, has a motor, or is motorsports related, you don't want to miss this **unique** event.

February 4, 2012

For tickets, visit
hatcherfoundation.org/pandora

The Coker Tire Museum

1317 Chesnut St.
Chattanooga, Tennessee

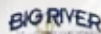



Pandora's European Motorsports
presents

PISTONS & FENDERS

to benefit the Austin Hatcher Foundation for Pediatric Cancer



AUSTIN HATCHER
FOUNDATION
for pediatric cancer

The Austin Hatcher Foundation is a Chattanooga based organization that supports families with child members stricken with cancer. Their mission statement: *"to erase the effects of pediatric cancer and optimize each child's quality of life through essential specialized intervention beginning at the time of diagnoses and continuing throughout survivorship."*

The founders of the organization are Jim and AmyJo Osborn. Jim is a well known spine surgeon and AmyJo a professional photographer. They are two personal friends of mine as well as Jim being a fellow motorsports race enthusiast... and most recently my doctor.

The name of the Foundation hails from Jim and AmyJo's firstborn son Hatch, whom they tragically lost to cancer at 9 weeks old. The story is heartbreaking and can be read in detail on their website, hatcherfoundation.org

There is a Hatch's House of Hope located within the Erlanger medical complex that acts as a sanctuary for families while their child is receiving treatment. There are toys, books, and games for

the children of the families, as well as psychiatrist offices, financial advisors, and schedule planners for the parents. These are the tools that families need to cope and thrive with the onset of pediatric cancer. All services are provided at no cost to the families and are funded solely by the generous donations of supporters like you. The long range plan is to open more Hatch's House of Hopes in hospitals across the country.

Jim first came into the shop shortly after we opened in 2010, and we immediately found common ground through BMW race cars, motorcycles, and discussion of various tracks in the Southern Region. It quickly became apparent that his passion for racing was shadowed by his passion for the Foundation, so it was a natural progression for the shop to adopt the foundation as it's chosen charity. In January of 2011 we had our first fundraising gala for the Austin Hatcher Foundation where 90 of our closest friends and customers came out in support. We had an evening full of laughter and some tears as we discussed the Foundation and the children it supports. We also took the opportunity to 'roast' some of our customers that just make it so easy!

This year Corky Coker, of Coker Tire, has donated his personal museum space for the event. We have auction items donated from Ducati, BMW, Porsche, Parts Unlimited, Tucker Rocky, Coker Tire, and many more. Our goal is to triple our attendance from last year. You can support the Foundation by signing up for the event! For \$100 a head you get all the food and drink you can handle, the entertainment of watching Corky auction off the items, and the pure amazement of walking through Corky's museum. There are cars and motorcycles on hand that represent virtually every era in motorsports development for the past 100 years! There is even an airplane hanging from the ceiling!...no joke!

Visit hatcherfoundation.org/pandora to register you and yours for the event.

Justin Prann
Pandora's European
Motorsports

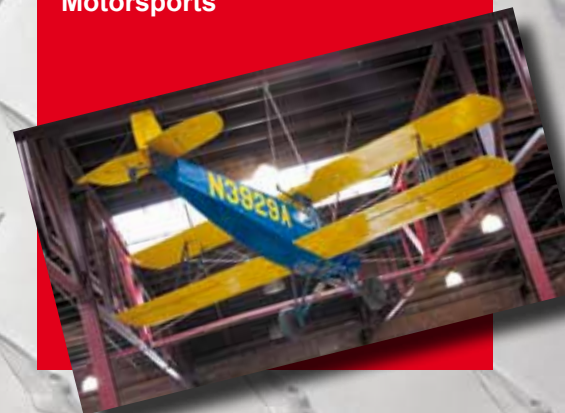

Childhood Cancer Facts

Childhood cancers are the #1 disease killer of children - more than asthma, cystic fibrosis, diabetes, and pediatric AIDS combined.

Childhood cancer is not a single disease, but rather many different types that fall into 12 major categories. Common adult cancers are extremely rare in children, yet many cancers are almost exclusively found in children.

Childhood Cancers are cancers that primarily affect children, teens, and young adults. When cancer strikes children and young adults it affects them differently than it would an adult.

Attempts to detect childhood cancers at an earlier stage, when the disease would react more favorably to treatment, have largely failed. Young patients often have a more advanced stage of cancer when first diagnosed. (Approximately 20% of adults with cancer show evidence the disease

has spread, yet almost 80% of children show that the cancer has spread to distant sites at the time of diagnosis).

Cancer in childhood occurs regularly, randomly, and spares no ethnic group, socioeconomic class, or geographic region.

The cause of most childhood cancers are unknown and at present, cannot be prevented. (Most adult cancers result from lifestyle factors such as smoking, diet, occupation, and other exposure to cancer-causing agents).

One in every 330 children will develop cancer by the age of 20. On the average, 12,500 children and adolescents in the U.S. are diagnosed with cancer each year.

On the average, 1 in every 4 elementary school has a child with cancer. The average high school has two students who are a current or former cancer patient. In the U.S., about 46 children and adolescents are diagnosed with

cancer every weekday.

While the cancer death rate has dropped more dramatically for children than for any other age group, 2,300 children and teenagers will die each year from cancer.

Childhood leukemia (making up the largest group of childhood cancers) was once a certain death sentence, but now can be cured almost 80% of the time.

Today, up to 75% of the children with cancer can be cured, yet, some forms of childhood cancers have proven so resistant to treatment that, in spite of research, a cure is illusive.

Several childhood cancers continue to have a very poor prognosis, including: brain stem tumors, metastatic sarcomas, relapsed acute lymphoblastic leukemia, and relapsed non-Hodgkin's lymphoma.

www.hatcherfoundation.org



WE ALSO SPECIALIZE IN GETTING PEOPLE AS EXCITED ABOUT RIDING THESE BIKES AS WE ARE.

THAT'S JUST TWO OF THE REASONS WHY WE SELL SO MANY BIKES . . . AND SO MANY PARTS!

CHECK US OUT
pandorasmotorsports.com



PANDORA'S EUROPEAN MOTORSPORTS
4784 Highway 58 - Chattanooga, TN
423-468-4104 - pandorasmotorsports.com
Follow us on Facebook
RIDE WELL.

BMW Motorrad
USA

Authorized
Dealer



In The Rearview Mirror Vintage



1972 Honda CL100K2

“Wag,” the original owner who was a friend and neighbor, bought the bike new in 1972. He and his son rode it in the woods for two years which accounts for the dents, scrapes and scratches in it’s three thousand miles. He then parked the bike in his garage where it gathered dust. I had been after him for years to sell it to me, but he never would until September 2009. He warned me it didn’t run. He sold me the bike and a “new” (unused) battery for sixty dollars. That’s the battery in it now.

I took the bike, which I call “Gerry” (short for geriatric), to Chattanooga State Community College where, with a replacement carburetor, the motorcycle tech people managed to get it running. It smoked like crazy, so we knew a major engine rebuild was in order.





Bob Edens

The hard part was acquiring parts for a bike that old, but Doctor Vince Langford, of Honda of Chattanooga on Highway 58, did a remarkable job of finding many parts. The rest came from searching eBay and included some parts from southeast Asia. Shipping cost was sometimes more than the parts cost.

Replaced the tires and tubes,

bore out the cylinder, added over sized piston and rings, replaced the timing chain guide and a valve, and I now have one hundred cubic centimeters of throbbing power between my legs, and it usually starts on the first kick. Gerry gives me from 75 to 85 miles per gallon depending on the wind, at up to a tad over 55 mph running back and forth in fair weather from Greater

Metropolitan Red Bank, TN, to work five miles away and now has 5,207 miles on him.

I keep the bike factory stock except for the automatic smile generator mounted on the handlebars on the left. It really works, and works well!

David McGlumphy

Fuel - Food - Clean Bathrooms - Riders Welcome!

JONES GAP RD. EXIT OFF HWY 111

Monday thru Saturday 6 am - 10 pm

Sunday 8 am - 10 pm

[423] 332-3360

Also Located In:

Dayton, Harrison, Cleveland, Benton, & Georgetown All Stores Locally Owned & Operated





WOMEN IN THE WIND

Tabatha

...and her chopped 250 Honda Rebel with TB custom paint

Meet **Tabatha Beachboard**. Tabatha has been riding for a little over two years and she's a pure natural. You can't help but admire her gutsy riding style and her love for riding. I had the pleasure of riding with her and there was no waiting on this chick; she was full throttle as soon as she cranked her custom chopped 250 Honda Rebel. Tabatha says, "I have to keep up with the guys 'cause they're all on much bigger bikes than me. I have to start off in 'haul butt' mode or I get left behind. That ain't going to happen!"

Tabatha not only loves to ride her bike, but she takes great pleasure in customizing it and working on it herself too. "I'm not scared

PAINTING
CUSTOMIZING
COLLISION REPAIR

QUALITY SERVICE FOR ALL MAKES AND MODELS

FULL SERVICE
FABRICATING
ENGINE REPAIR

The Hogs Pen

MOTORCYCLE REPAIR

ACCESSORIES

1018 SALEM RD
ROSSVILLE, GA

WWW.THEHOGSPEN.COM

TUES-SAT 10-6
706.861.4647

BUDDY'S SHOE REPAIR
LEATHER REPAIR

- ✓ Vests: Patches sewn & worn snaps replaced
- ✓ Chap Repair and Alteration
- ✓ Saddle Bag Repair
- ✓ Holster & Sheath Repair & Customization
- ✓ Customized 100% Leather Belts & More
- ✓ Boots to Flip Flops: We repair almost everything!
- ✓ Full supply of Leather cleaners & conditioners
- ✓ Misc: Orthopedic build ups, baseball gloves, purses, wallets, and more.

FAMILY OWNED
OPEN FOR OVER 105 YEARS

Open Mon, Tues, Thurs, Fri 9 AM - 5:30 PM
Sat 9 AM - 2 PM
CLOSED Sunday and Wednesday

423-870-8911

5221 Hixson Pike Hixson, TN 37343
About 4 blocks north of Northgate Mall
Next door to Maxi Muffler

to get dirty,” she says, “its driveway built.” When she first got her bike, the carburetor needed to be rebuilt and the paint had to go. She rebuilt the carburetor herself and then set to work on the paint. She painted her frame pink and christened her “Princess.” She says she created stars on her tank using flat black paint and, “257 stickers; I used 43 for practice.” Her next step is to rewire the entire bike. I asked her if she’d do that too and she replied, “Of course. It’s not like I haven’t messed with it before; I’m always catching and fixing shorts.”

One of her frustrations of working on her own bike is the response she gets from the male population. For example, at Nightfall one evening her bike wouldn’t start. Tabatha says, “Suddenly, all these men floated around and pushed me away from my bike. I said, ‘Wait a minute’ and pushed back through, fixed the problem, and fired her up. That was a good feeling.”

“I have to keep up with the guys ‘cause they’re all on much bigger bikes than me. I have to start off in ‘haul butt’ mode or I get left behind. That ain’t going to happen!”

One of Tabatha’s favorite events is the Smoke Out; She’s even made the ultimate sacrifice the past two years by driving the chase vehicle with her bike in back, because she was told her bike couldn’t



Kim Teems

keep up. She says, “I did ride the heck out of it at the Smoke Out though, and I plan on upgrading to a bigger bike so I’m not the chase vehicle anymore, but don’t worry because ‘Princess’ will stay in my living room when that happens. She’s paid for.”

Tabatha stays busy with work, her fiancé Grayson, and three kids Harley, Kayla, and Drea, who all like to ride too! “Many a time I’ve ridden the kids to the bus stop on ‘Princess,’” she says, “they LOVE it.”

With such a busy life I asked her when she found the time to ride, which she replied, “I ride to work all the time. I grab every chance I can get. I love the wind in my hair. I like the

way people look at me ‘cause I’m a woman on a bike, especially the little girls ‘cause they see it’s cool for a girl to do a traditional ‘boy thing.’ I like the fact that I can go fast and get that rush of wind and speed. I love the freedom...just get on and ride!”

I enjoyed getting to know Tabatha and hope you did to. If you see her zooming past you on her 250 chopper, check out her cool paint and give her a wave. **She’s truly a Woman in the Wind.**

Kim Teems
kim@kickstandup.com



MOUNTAIN CITY LANDSCAPE

423.622.9090

MX CARBS

Competitive activity requires extra energy intake. Riding or Racing Off road certainly falls into this category. Dietary plans that provide the most efficient energy sources will help the athlete succeed. Carbohydrate Loading is a well-entrenched strategy. Several factors influence the energy required for a success. The type, intensity and frequency of training as well as size, age, and sex are major factors that influence energy needs. Such as a weekend warrior's energy needs are much different than a seasoned professional's.

There are three sources for energy carbohydrates, fats, and proteins. Proteins are used primarily for growth, maintenance, and repair, rather than an energy source. In fact, high use of protein for energy proves to be inefficient and may lead to liver and kidney problems. Carbohydrates and fats are your best choice for fuel for all types of activities. Carbs are used as the initial fuel, especially where short bursts of energy are needed. The combination of Carbs and Fats are used for more sustained energy.

The body stores limited amounts of carbohydrates as glycogen. The amount of energy used from glycogen is about 1900 calories. When these

stores run low, so does your bodies performance levels.

Carbs are the best overall source of energy. In fact, Sports Nutritionists recommend that 55 to 65 percent of intake calories come from carbohydrates. However, these nutrients should be used in accordance to (1) Training goals (2) Time of day, and (3) Body Type. The old concept of Carbohydrate Loading revolved around depleting the carbohydrate stores then replenishing them day's prior to competition. This technique had some ill effects.

The modified plan will call for a carbohydrate intake of 530 grams or 65 percent of all calories from carbohydrates three days prior to competition. However, it should be noted that intake higher than this will not contribute any significant advantage and may even be more harmful. Nutritionists recommend 50-60 grams of carbohydrates per hour to fuel most athletes.

Fat is another important fuel source. Aerobic training increases the body's ability to use fat as a fuel. However, fat cannot be used exclusively, because Fats breakdown process produces a waste byproduct that will in fact limit stamina.

Carbohydrate Loading should only be done with the advise of a Health Care Professional.

**A Riverpark Chiropractic Center
Dr. Danny Thompson, BS, DC**



Chix MX's year has started off rather well. We have been approached by **Kelsey Greene**, who puts together the **"Girls Just Wanna Ride Day"** every year in Hanover, Pennsylvania, to help sponsor the camp this year on May 26th. We are honored to accept and are excited to participate in this awesome event that gets girls out on dirt bikes and show that they can do it.

The whole event is to promote females to ride and even race if they desire and not to be inhibited by the predominately male sport of motocross, because girls can also get out there and do it.

The event has several female pros to come and instruct younger, less experienced girls basic skills on the bike. They are also there to help more experienced girls to improve the skills that they have already acquired. All in all, it's just a fun day for girls with a mutual interest to come together and have a good time.

If anyone is interested in participating, contact me at darlene@chixmx.com, and I will send you information for registration.

www.chixmx.com

Tammy Jo Kirk's
NW Georgia's Honda Dealer

KIRK'S CYCLE
706-226-4090

Motorcycles
ATVs • Scooters • MUVs
Generators for Sale
Parts • Service • Accessories

DALTON, GA • 706-226-4090
KirkCycle.com



In The Headlight Jessi



Courtesy of Jessi Handford

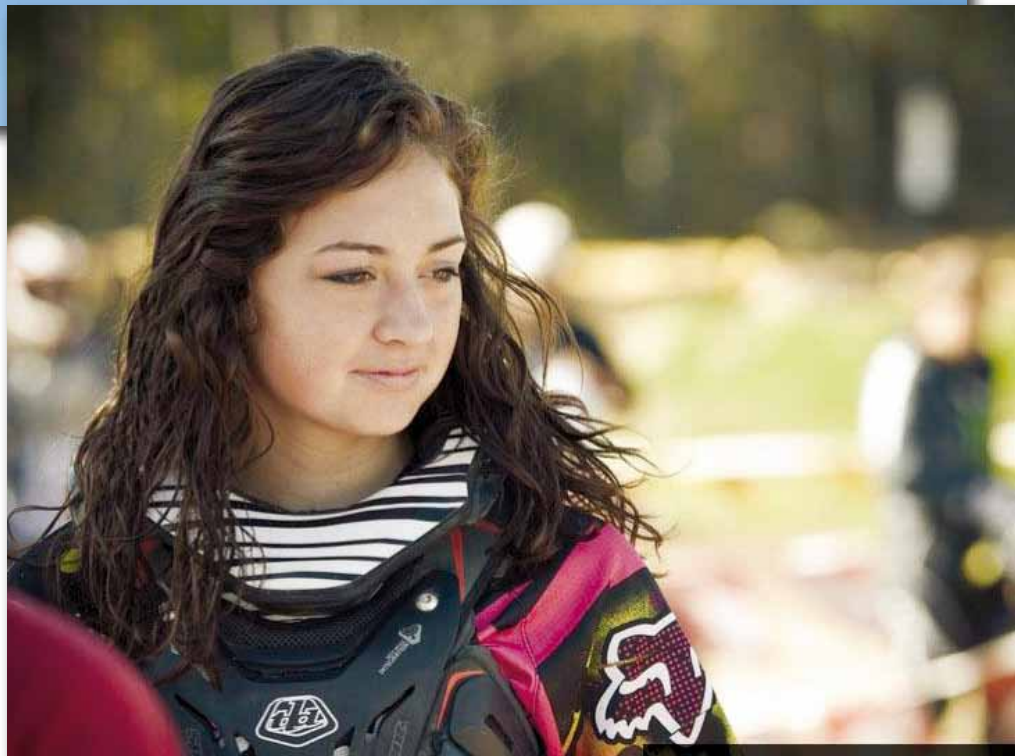

Jessi Hanford from Pensacola, Florida, is a very talented 15 year old amateur motocross rider. Her interest in motocross came at an early age where her father was into racing, hence, she was pretty much grew up at the track. Not to mention, that her grandpa held a pro license and raced his entire life. To say the least, motocross runs in her blood.

Jessi received her first bike, a PW50, at 4 years old. She began racing at the age of five.

This past November on Thanksgiving week, Jessi got an 5th overall at the Mini O's Nationals at Gatorback MX near Gainesville, FL. Having raced at several Nationals such as the Mini O's, Spring Classic, and Loretta Lynn's Amateur National Championship, she has gained much needed experience on a full gate with the fastest girls in the nation.

Jessi currently rides a KTM 105. She has trained at MTF, Justin Summers track, and County Line MX. Her favorite track is Monster Mountain near Montgomery, Alabama.

Her goals for the 2012 season is to finish in the top 5 at Loretta Lynn's and the Mini O's Nationals. Jessi's long term aspirations are to be one of the top women pro motocross riders. Jessi said **"I would also like to help take women's motocross to the next level and put it on an even playing field as men's motocross."**

Besides motocross, she also enjoys mountain biking and working out. She is sponsored by Chix MX, Kiss My X gear, FMF, Renthal and D2-1 Air Filters.



FUN DAY IN THE DIRT!

New Years Eve at Battle Creek MX - GP Style

ALL SPEED AND NO JUMPS

Battle Creek MX kicked off their first GP style race on a sunny New Years Eve. The weather was perfect, the track was a little wet but the 123 entries had a great time. The event had classes for everyone as well as several unique classes; such as, the 40 minute + 2 lap Iron Man, a 3 rider Team race, ATV's and vintage classes.

If you missed this race, don't worry, Battle Creek MX has plans to host more GP races throughout 2012. After talking to Darrel, he has some great ideas for the future GP's and more of their property will be available for an even bigger, better track layout. Make sure you DO NOT miss the next GP! This was my first time attending a GP and it will not be my last! What a fun day in the dirt!

Zack Cummings
zdcphotos.com

CLASS WINNERS

- Iron Man:** Seth Derryberry (Rising Fawn, GA)
- ATV Open:** Matt G. Quarles (Rocky Face, GA)
- Women's Class:** Abigail M. Jacks (Rossville, GA)
- Vintage Pre 1975:** Rick Lange (Dahlonega, GA)
- Vintage Pre 1985:** Matthew J. Bell (Chattanooga, TN)
- Run Whatchya Brung:** Shannon Amos (Chatsworth, GA)
- Plus 25:** Jacob Brookshire (Acworth, GA)
- Plus 35:** Michael R. Crane (Acworth, GA)
- 14-24:** Tyler Trammell (Dahlonega, GA)
- Junior Mini 50cc Open:** Tyler Davenport (Gainesville, GA)
- Mini 65cc Open:** Gage McBee (Dalton, GA)
- Plus 45:** Michael R. Crane (Acworth, GA)
- Sr. Mini:** Darren Hicks (McMinnville, TN)
- Team Race:** Team GRF



Zack Cummings



AMA SUPERCROSS

2012 Greatest Season Ever Is Underway!

The Supercross season has begun, and the contenders from last season's "Greatest Season Ever" are giving us an encore. The season opener at Anaheim gave us an idea of how this season may go, but it is still anyone's championship. Ryan Villopoto showed the rest of the pack how he was going to ride right out of the gate. He took the hole shot in the main event, and never looked back. His ride was smooth, with only one hiccup. He commented on how much his team prepared for this, and it paid off. He stayed out front, and stayed focused. If he can maintain this attitude and focus, the competition is going to have to pull every trick up their sleeves to beat him.

Chad Reed took second place early on, and rode well. He had lost about ten seconds on Villopoto, but was still about 8 seconds ahead of Dungey. That is until he grabbed too much brake going into a right hander, and quickly had Dungey and Stewart breathing down his neck. He managed to throw his leg back over his bike, and salvage second. He put in a good ride, but if he keeps making small mistakes like that, he's going to have some major competition from the likes of his arch nemesis, James Stewart.

Ryan Dungey put in a good, solid ride. He maintained a good third for the first part of the race, but about midway through, Stewart had caught up and was riding Dungey's rear fender. He had some competition, but had some good luck, and maintained his podium finish. Dungey is not known for being aggressive, like we saw him on his Championship-winning season. This is his greatest challenge because this is an aggressive sport. If he wants to keep making podium finishes, he needs to step it up and not be afraid of block-passing somebody to gain a position.

Stewart got a bad start, and had to fight his way through the pack. By the end of the first lap, he had fought to sixth position, and had even had some resistance from an old rival, Ivan Tedesco. It wasn't long though until he was fighting for third with Dungey. Though Dungey put up some resistance, he managed to get by. He was fast, and doing great until his old demon came to haunt him. He went down when he ran into some tuff blocks when he got too far to the left. After that he went at an average pace, and the commentators said that he didn't look like himself out there. It could have been fatigue, frustration, lack of concentration, or any number of things, but he was not riding like himself. We will see if this was a fluke or if he will have his head in the game for the rest of the season. We all know he could compete with Villopoto if he just keeps it on two wheels.

This Supercross season has started off with a lot of speculation and excitement, and I look forward to watching it week after week. The eventual champion is still a mystery and all we can do is ask... Who will win it?

Jeff Griffith
jgriffith@griffithcycle.com

Live your Life...



ON PURPOSE!

423-867-0423 | 4704 DODDS AVE | CHATTANOOGA, TN 37407

\$60/hr labor rate

GARRY GRIFFITH CYCLE



We work on most makes and models

GRIFFITHCYCLE.COM

Best deals on Motorcycle Tires



THE QUICKEST & BEST PRINTER IN TOWN!



KickStand Up!
Available Here 24/7

www.quicktees.com

Between Germantown Rd. & The Comedy Catch

QUICK TEES
3472 Brainerd Rd. **on Brainerd**

Ronnie "Rock" Land
Owner

423.697.1856

HAVING A CHARITY EVENT?

**We Will Beat Any
Price in Town!**

(Just bring in your written estimate
from one of our competitors.)

THE RIDE ALONG MAUI'S COAST TO HANNA



Cheryl Lozon



Jim Lozon

The road to Hanna is 52 miles long with 617 curves, 56 bridges...

It was a typical Maui morning, mid 70's sunny with a light breeze. We picked up the rented street glide and headed for the road to Hanna. The road to Hanna is 52 miles long with 617 curves, 56 bridges most of them one lane and countless breathtaking stops along the way.

We started down the coast from the Northern town of Pa'ala along the North coast and watched the windsurfer's taking advantage of the beautiful morning waves.

We continued along the winding road using much of the sidewall on the Street Glides wide front tire. The speeds along the road to Hanna are quite low 15 to 25 miles an hour in most curves. Around every curve

there just seems to be another discovery of a waterfall or Bamboo field. The Mountain apple trees had dropped some of their flowers to make a bright Red carpet under them. Further along are the Rainbow Eucalyptus trees that have no bark on the trunk. Just a smooth rainbow like finish that is even more pronounced when wet.

Did I say wet, yep you can count on a short rainfall on your trip to Hanna as it is the rainforest. If memory serves me correctly, they told me that area gets 365 inches of rain a year. Don't let that distract you though, the ride is usually only wet for a few miles then you are back to paradise.

About halfway through the ride will take you to the Ke'anae Peninsula to take in more beautiful sights. That is where the pictures are from. The waves crashing along the shoreline most times are 15 feet high. The rest of the road down to Hanna is nothing short of spectacular.

With all the stops along the way to take in the sights and get some pictures your trip to Hanna will take around five hours. Then you can make the decision to go back or continue to the Seven sacred pools in Ohe'o, which is in Haleakala National Park in Kipahulu. This is a must see attraction in my opinion.

At this point you do have to turn around and go back out the way you came in as there are no paved roads to continue any further south. So take your time enjoy all the sights along the way down, stop often as you will miss many beautiful sights along the way if you don't. Now for the icing on the cake! Get on the scooter and enjoy every inch of that curvy road on your way back. It is a ride you will never forget!

Jim Lozon
KSU Facebook Fans

Killboy.com

The ORIGINAL
Dragon's Tail Photographer

Dodd & Associates Training

THE BEST DEFENSE IS A GOOD OFFENSE

FIREARMS TRAINING
2107 Leggett Road – Sale Creek, TN 37373
423.877.0399
doddtraining.com

DISCOVER Little River Canyon

Most people have heard of Little River Canyon (near Ft. Payne, AL), but many riders haven't experienced one of the most spectacular gorges east of the Mississippi. My route takes about an hour and a half one way. You'll travel a lot of cool country back roads and the scenery is great. My route has a very steep ascent and is probably not for newbie's. There is a tamer way to see Little River Canyon if you come in from the Ft. Payne direction. If you are in a hurry, catch I-59 in Ft. Payne for a faster trip home. I guarantee you that once you experience this amazing place you will return time and time again. Each season has something different to offer. Even in the summer the traffic is light, while in the winter you might not even see another vehicle. It's a magical place.

Little River is one of the nation's longest rivers that forms and flows for most of it's length atop a mountain (Lookout Mountain.) The river plunges off the mountain at the head of Little River Canyon. The canyon is one of the most extensive canyon and gorge systems in the eastern United States and one of the South's clearest, wildest waterways. The river is small in the summer, but surges with the rainfall in the cooler months. Although it is impressive during the summer with the canopy, it is much more impressive after the leaves have fallen. Then you can see the real depth of the gorge.

Congress added Little River Canyon to the National Park System in 1992. The Preserve protects 14,000 acres of the 199 square mile Little River watershed and many rare, threatened, and endangered species of plants and animals.

Ronnie Land
ronnie@kickstandup.com

DIRECTIONS FROM CHATTANOOGA/EAST RIDGE 41 SOUTH

- LEFT onto 151 S
- LEFT onto 136 E
- RIGHT onto 201 S / E Armuchee Road
- RIGHT onto GORE SUBLIGNA RD
- CROSS 27 / Turns into JOHN JONES ROAD
- STOP SIGN bear RIGHT / SILVER HILL ROAD
- LEFT onto 100 S until Tee
- RIGHT onto OLD ALABAMA HWY
- RIGHT onto 35 W
- LEFT onto 273S
- RIGHT onto CR 275 - Follow to LRC

Note: This route is NOT for Newbies and has a very steep ascent. For an easier route, get to Ft. Payne then take 35 to the main entrance of Little River Canyon

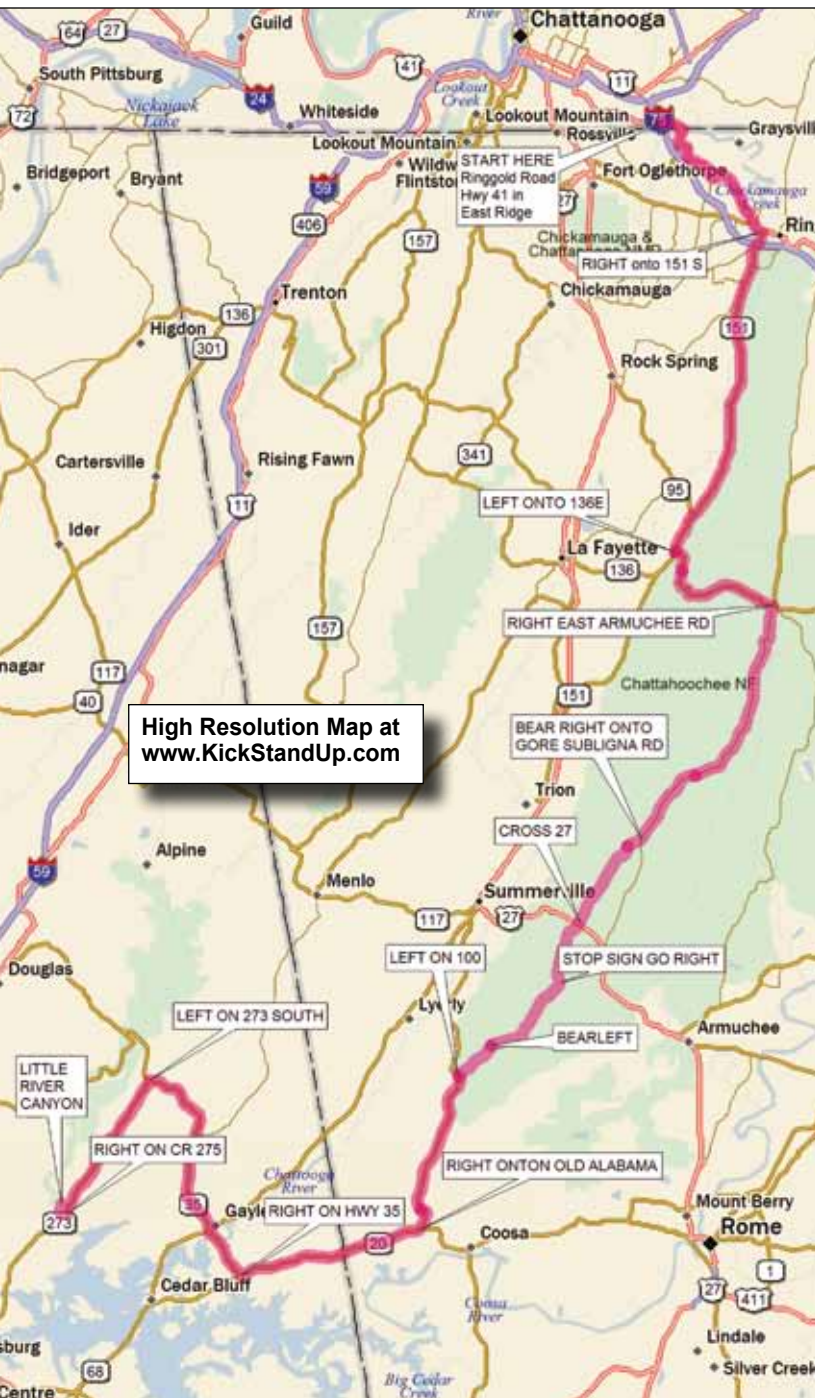

STROKER CYCLE LLC

Open 7 days - 7:00 am until ?

11320 Thatch Rd. - Harrison, TN 37341

Repair - Parts - Service

Chroming & Powder Coating

Pick-Up & Delivery Available

www.strokcycl.com

NOW ACCEPTING



423-344-2571



MIDWEST V-TWIN



Area's Only Authorized Dealer for:

FRANKENSTEIN TRIKES

for HARLEY-DAVIDSON'S

Saggy Bags Restoration Systems

Extended Warranty Certified

Drag Specialties

ROBERT PARTEE
Owner

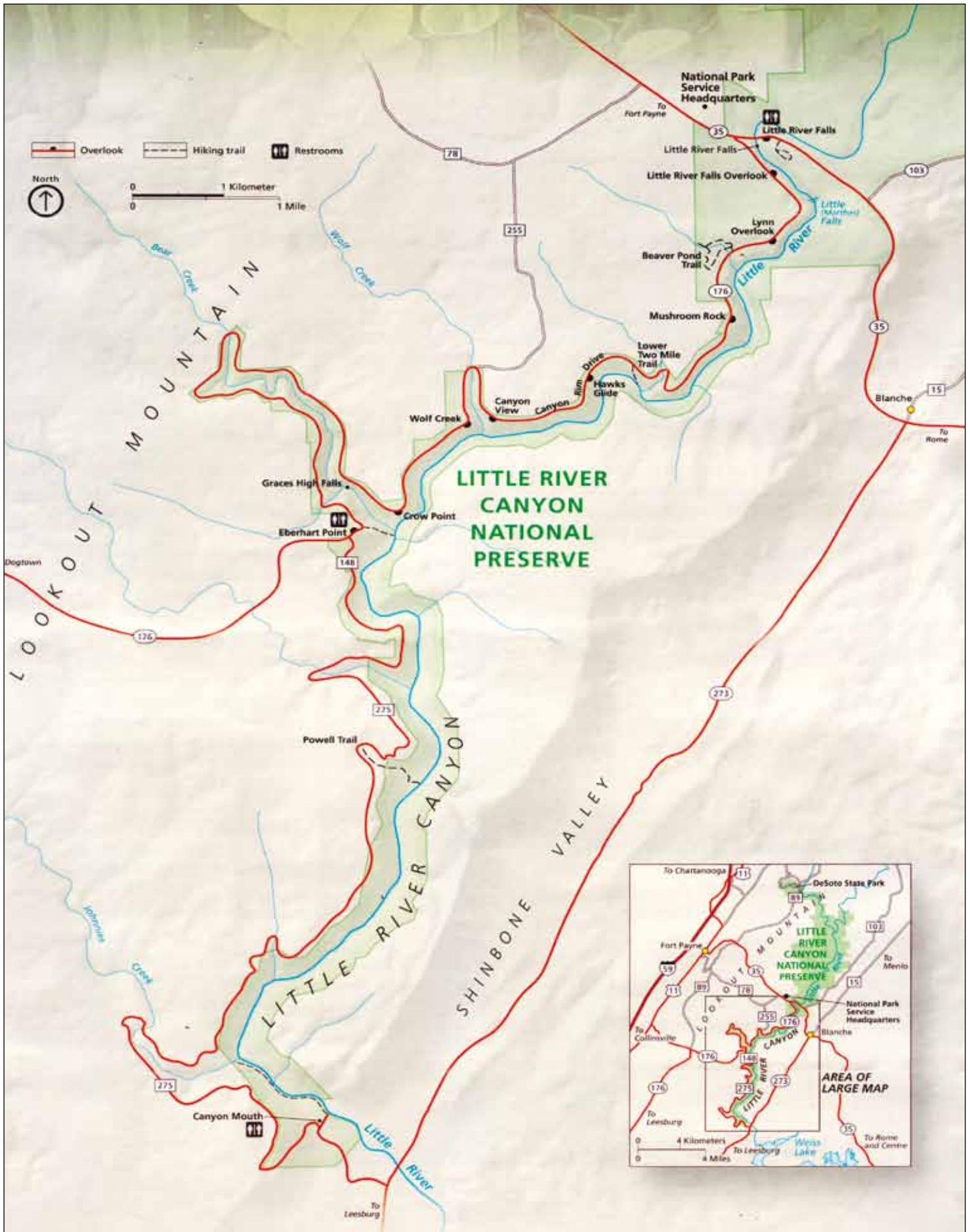



**WHITE COTTON
LEATHER COMPANY**

**FIRE SALE 20% - 50%
Off Selective Items**

MOTORCYCLE APPAREL

For Men, Ladies, & Kids

Custom Patches & Minor
Leather Repair

Mon-Fri 9-5, Closed Sat. & Sun.
ACROSS STREET FROM OLD LOCATION

Hamilton St, Dalton, GA

706-278-8191

Toll Free 1-888-877-1217



SEQUATCHIE VALLEY WINE & SPIRITS

Hwy. 111 & 127 across from BP Station

Dunlap, Tennessee

423-949-3348



RIDES & RODS

Buddy & Dollie Martin

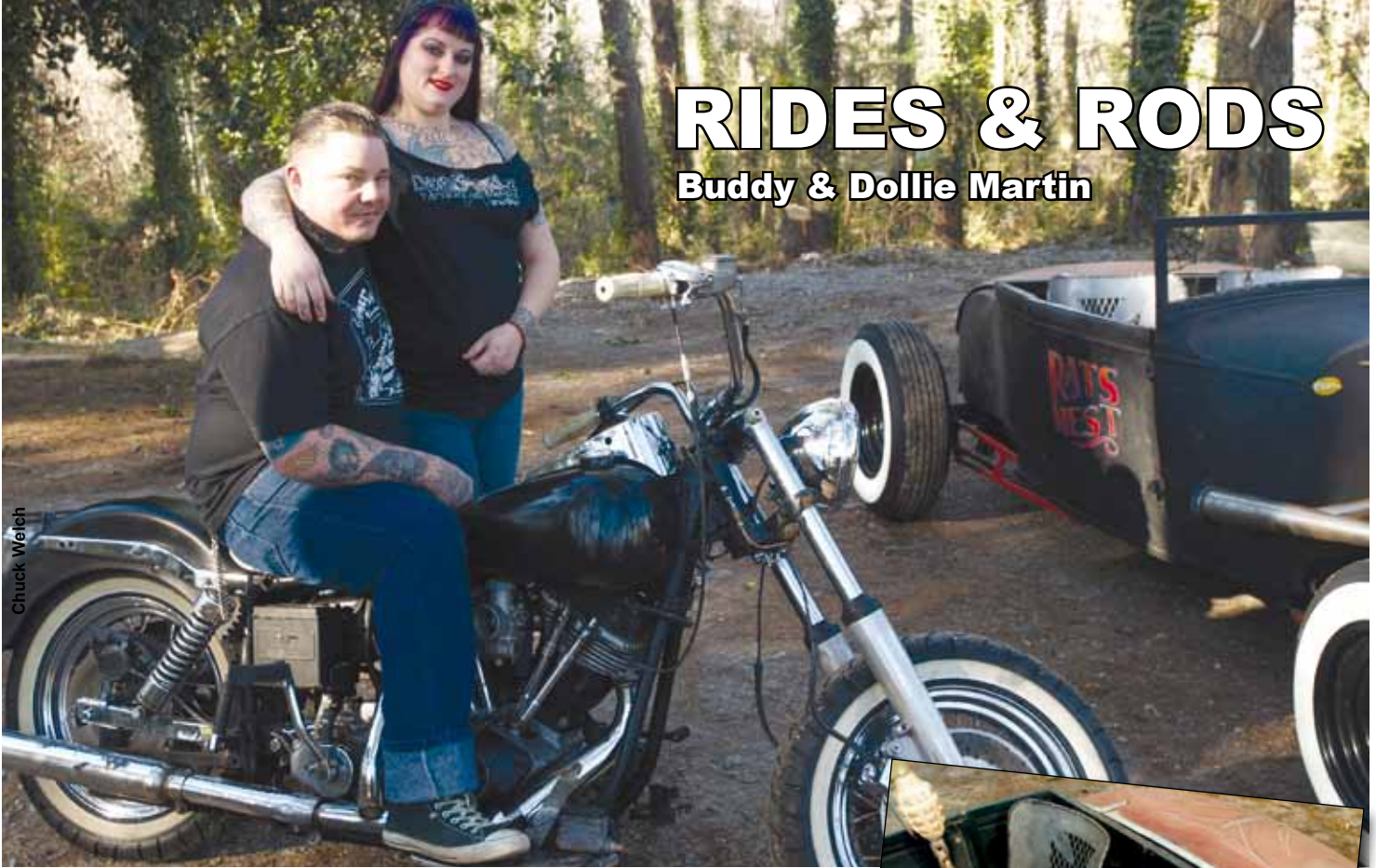

Chuck Welch

Rides: 1976 Harley-Davidson Shovelhead, 3 inch open primary bobber seat, and white wall spoke radial with original 1200 chrome swing arm dual chrome calipers.

Rod: 1931 Model A Roadster "Rats Nest" pinstriped rear trunk, Coker Classic white wall tires, custom body work, spider web window, front skull and web grill, 305 Chevy 4 speed Saginaw trans, disc front and drum rear brakes, and headers by Buddy, "Iron Ace" Bomber seats and rocker arm head light mounts.

Honest James (Buddy) Martin works for Honest Charley's Speed Shop. Dollie runs **Dead Girlz Tattoos** [Check out their

ad below]. Buddy and Dollie are a unique couple and it was a pleasure getting to know them. Thank you for letting KSU into your world.



Chuck Welch
chuck@kickstandup.com



Riding to Remember

Chattanooga, TN to Florence, AL

SEPTEMBER 14 - KICKOFF PARTY AT THUNDER CREEK H-D

SEPTEMBER 15, 2012

EXTENDED RIDE

Florence, AL to Oklahoma

Sept. 16 -17 , 2012



www.TrailOfTears-Remembrance.org

877-868-8747

This ride not affiliated with any Trail of Tears ride other than the "Charlie Maxwell Ride" from Cartersville, GA, "Cherokee NC Ride", and the "Cherokee Northern Route Ride" from Kentucky all of which take place on Friday, September 16, 2011. Trail of Tears Remembrance Ride is organized by a 501 C3 non profit Board of Directors



deadgirlz tattooboutique.webs.com

Custom Tattoo & Body Work

Handmade boutique items by local artists

423-320-2652

1870 Cloud Springs Rd,
Rossville, GA



The World Famous Smoke House

Featuring Live Nashville Songwriters

The World Famous **Smoke House** features Live Nashville Songwriters, performing their own songs, in a pleasant Non-Smoking and Family Friendly Atmosphere. Food and beverages are served from the Smoke House extensive menu. Come see up and

coming songwriters as well as some who have had hits by big Country Music Artists. Lodging available in our Updated Lodge Rooms and Rustic Log Cabins featuring fireplaces, Jacuzzi tubs, front porches, kitchens, 1 to 5 bed room Cabins available.

"Live Nashville Music"
6:30 pm-9:30 pm CST.
NO COVER! Every Friday and Saturday

Night at Jim Oliver's Smoke House , 850 West Main St., Monteagle, Tn. **"Bluegrass Friday"** on every fourth Friday of every month! Check out our music schedule at: www.TheSmokeHouse.com

February 10-12th – Successful Songwriting at the Smoke House' Louisa Branscomb & Friends Songwriting Workshop Monteagle Mountain Mastercraft Series #1.

We will be having performances both Friday and Saturday, 6:30pm-9:30pm CST. This will be FREE to the public to enjoy. However, to participate in the workshop and to perform the cost is \$300 (Does NOT include food or lodging). For more information or to register: www.SuccessfulSongwriting.com

March 23-25th – Smokin Hit Songwriters" Seminar/Retreat.

We will be having performances both Friday and Saturday, 6:30pm-9:30pm CST, featuring an open-mic contest on Friday night by the first 30 participants to register. Saturday night will feature a Nashville Style Round w/ Mega Hit Songwriters Dave Gibson, Jerry Hannan & Wynn Varble! This event will be FREE to the public to enjoy. However, to participate in the Seminar/Retreat and to perform the cost is \$195 (Does NOT include food or lodging). For more information or to register: www.SmokinHitSongwriters.com

MUSIC ON THE MOUNTAIN
THE BEST OF NASHVILLE EVERY SATURDAY 7:30 PM
BEER & WINE COOLERS AVAILABLE

Jim Oliver's

SMOKE HOUSE RESTAURANT TRADING POST

TRAIL OF TEARS
REMEMBRANCE MOTORCYCLE RIDE
OFFICIAL SPONSOR TRAIL OF TEARS

GREAT FOOD
RUSTIC DINING
CABINS & MOTEL

Best Western
Smoke House Lodge

SINCE 1960
Jim Oliver's SMOKE HOUSE RESTAURANT
OPEN EVERYDAY

NO COVER CHARGE
COZY ATMOSPHERE

LIVE NASHVILLE MUSIC
EVERY SATURDAY NIGHT

WELCOME!
MONTEAGLE TENNESSEE

WE SUPPORT AREA RIDERS
RIDERS WELCOME

www.thesmokehouse.com

OLD GENERAL STORE
(800) 489-2091 (931) 924-2091



HUDLOW AXLE
AXLES | DRIVE SHAFTS | GEARS & MORE

- 4 X 4 SPECIALIST
- CUSTOM FAB WORK
- FULL MACHINE SHOP
- WE BUILD CUSTOM STEEL & ALUMINUM DRIVESHAFTS
- ALL SHAFTS ARE GUARANTEED BALANCED
- CUSTOM AXLE SPLINING & REDRILLING

417 West Lake Ave., Rossville, GA
423-362-3006
 HudlowAxle.com

Classifieds

FOR SALE 4.8 ACRES OFF REDBUD AND BEHIND Lowes on Hwy 2, Fort Oglethorpe, GA. Contact Hugh Teems at 423-304-9480

GRIFFITH CYCLE VTX1300R SALE: We have 3 clean and serviced Honda 1300's. Check them out on our website, come in, test ride, and get riding! We have easy financing readily available. www.griffithcycle.com or call Garry at (423)867-0423

GRIFFITH CYCLE carries a full line of AMERICAN MADE ARCTIC CAT ATV'S AND SIDE BY SIDES! Get in the woods and enjoy nature! Be ready for the SNOW or enjoy FARMING! RULE MT. AETNA with the baddest ATV made! Check out all of our ARCTIC CATS and motorcycles at www.griffithcycle.com or call (423)867-0423. 4704 DODDS AVE. The cycle shop you grew up with!

Got BAD CREDIT or NONE at all? We can get you financed at Thunder Creek Harley-Davidson and put you on the bike of your dreams. Call or come by for details 423-892-4888

WANTED: If you have a car, boat, or dirt bike, and would like to trade for a Harley we would like to speak to you, At Thunder Creek Harley-Davidson if we can put a value on it, we will take it on in on trade. Come by and see us or give us a call 423-892-4888

PLACE YOUR CLASSIFIED HERE!

\$15 for 25 Words or Less. Submit your classified ONLINE at KickStandUp.com/classified.html or SNAIL MAIL your classified along with check or money order to:

KickStand Up! Magazine
 3472 Brainerd Road,
 Chattanooga, TN 37411

AMSOIL
 The Most Advanced Motorcycle Oil on the Market

THUNDER CREEK HARLEY-DAVIDSON Chattanooga, TN 423-892-4888	POWERSPORTS SOUTH South Pittsburg, TN 423-802-7316	MOUNTAIN CREEK HARLEY-DAVIDSON Dalton, GA 30728 706-370-7433
CUSTOM COATERS Crossville, TN 38555-4303 931-484-7300	CASTLES OUTDOOR CENTER Whitwell, TN 423-658-0008	HOG HOUSE Dunlap, TN 423-580-9934
SALE CREEK POWERSPORTS Sale Creek, TN 423-451-7036	DUNLAP FAST LUBE Dunlap, TN 423-949-6157	BATTLE CREEK POWERSPORTS Jasper, TN 423-942-9056

Chattanooga's Premier Custom Powder Coater

AUTOCYCLE POWDER COATING

1920 Dayton Blvd. - Red Bank, TN.
423-463-4760
 AutoCyclePC@gmail.com
 www.facebook.com/autocycle.powdercoating
 www.AutoCyclePC.com

Se Habla Español

Authentic American • Southern • Soul Food Buffet • Family Recipes • Reasonable Prices

**Mention KSU &
Get a FREE DESSERT**



- Private Party Room Open for Special Events
- Birthday & Christmas Parties, Club Meetings, Wedding Rehearsal Dinners, Family Reunions, Anniversaries
- Custom Menu Available for Events

Fresh Food

DAILY SPECIALS
Lunch & Supper Served
Tues. - Sat. 11 am - 8 pm
Sunday 11 am - 3 pm
Closed Monday

www.TheWisteriaCafe.com
423-847-1163



Wisteria Cafe

6849 Prestige Lane, Suite 117 at the Corner of Boy Scout and Middle Valley Rd.

Dallas Bay Baptist Church Presents

Now Showing in **February 2012**

SHOWING February 7th Countdown to the apocalypse	SHOWING February 14th Exclusive interview with the author of the best seller <i>The Shack</i>
SHOWING February 21st Is science going too far?	SHOWING February 28th A daughter's dilemma

LifetreeCafe.com



Northgate Campus &
Conference Center
Tuesdays @ Noon & 7pm
Hixson, TN
(Across from Chuck E. Cheese)
423.842.9299 dbbc.org

*"An hour of stories
and conversation to
feed your soul."*

The Talk
of the Town



"Doing life. Doing good."



**'Cause you
never know
what you
might
run into.**

I'm your agent for that.

Having me as your agent means having a real person there to help you when you need it. So when accidents happen, you have someone you can trust to get the job done right, and right away.

**Like a good neighbor,
State Farm is there.®**

CALL FOR A QUOTE 24/7.



State Farm

Rodney Allen, Agent

8521 Hixson Pike
Hixson, TN 37343
Bus: 423-847-3881

rodney.allen.lozg@statefarm.com

1001177

State Farm Mutual Automobile Insurance Company
State Farm Indemnity Company • Bloomington, IL



**CAUGHT
IN HEADLIGHT
WORLD OF WHEELS**
See More Photos at
KickStandUp.com



Gregory Cook & Chuck Welch





CAUGHT IN HEADLIGHT
SOUTHERN CRUISERS POLAR BEAR RUN
PANDORA'S & CHATTANOOGA TOY RUN
SEE MORE PICS AT KICKSTANDUP.COM





**From:
Children's Home/Chambliss Shelter:**

Dear Derrick/Steel Brothers MC,
Please relay our heart felt thanks to everyone involved in the Chattanooga Toy Run for CHCS on 12-17-11. It is truly amazing to think there were 540 participants in your group this year! Thank you for the wonderful donation of toys and for coming to the Children's Home to provide cookies and hot chocolate for the children and let them see and sit on some of your motorcycles. We deeply appreciate your friendship and support and pray God will give you many blessings in 2012.

**Most Sincerely,
Paulette Acord
Director of Volunteer Services**

**From:
Steel Brothers MC:**

Receiving this letter, I felt it was appropriate to share with each of you. Obviously, there are not 540 Steel Brothers so, it was you/your friends/your family that made this event the success it was. We are already taking steps to improve 2012's event in hopes that it will be an even greater success!!!



**CAUGHT IN HEADLIGHT
CHATTANOOGA TOY RUN FOR CHCS
SEE MORE PICS AT KICKSTANDUP.COM**



Frank Pate, Chuck Welch

TRUE LOVE, HARLEY STYLE.

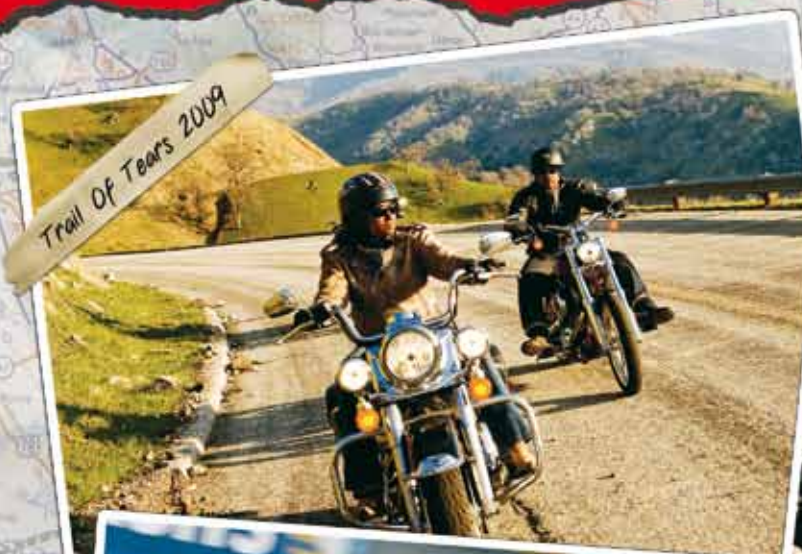

Trail Of Tears 2009

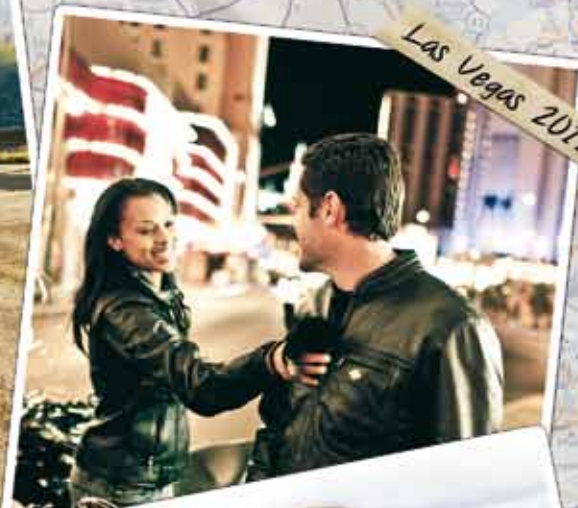

Las Vegas 2011



Sturgis 2008



Bike Week 2010



Find your true love today at:

THUNDER CREEK H-D
7720 Lee Hwy. Chattanooga, TN
(423) 892-4888

MOUNTAIN CREEK H-D
1001 Market St. Dalton, GA
(706) 370-7433

TIFTON H-D
49 Casseta Rd. Tifton, GA
(229) 387-8855

www.thecreekhd.com